

# TV-2110B

## VERTICAL MACHINING CENTER

With FANUC 18MC Control



### FEATURES

- Powerful 30 HP Spindle Output
- 622 Ft.-lb. of Torque at 209 RPM
- 6,000 RPM Maximum Spindle Speed
- True 2 Speed Geared Head Spindle
- Oilmatic Spindle Cooling System
- Unique One Piece Base and Pan Design
- Table Overhang-Free Design (Patent Pending)
- Rugged Meehanite® Castings
- Automatic Central Lubrication System
- Remote Manual Pulse Generator
- Dual Chip Augers & lift-up Chip Conveyor
- RS 232C Interface
- Fast 4 Sec. (T-T) Swing Arm ATC System
- Bi-Directional, Random Access 30 Tool Magazine
- Full Alphanumeric Keyboard
- AC Digital Servo & Spindle Drives
- Oil Skimmer is a Standard Accessories
- Rigid Tapping & Helical Interpolation
- Precision Hardened & Ground Ballscrews
- Hardened & Ground Box Ways
- Heavy Duty Coolant Pump
- Cutting Air Blast System
- Spindle Air Blast System
- Maximum Table Load: 15,000 lb.

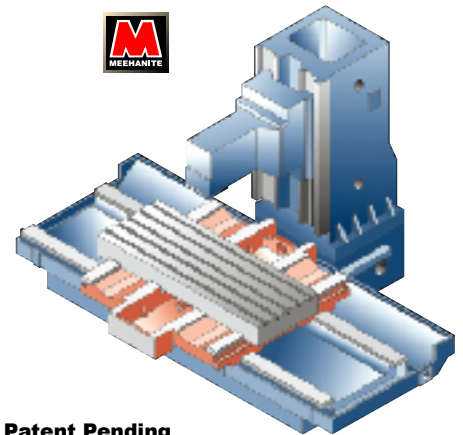

Patent Pending

**YCI SUPERMAX®**  
PRECISION MACHINES

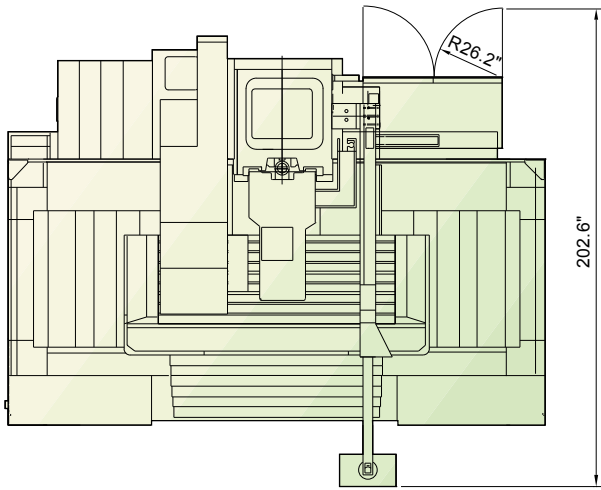

UNIT: Inch

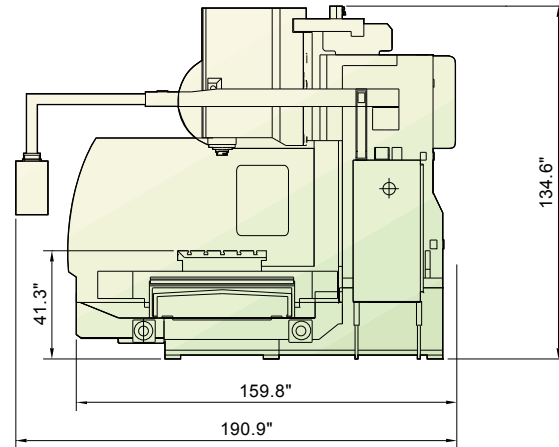
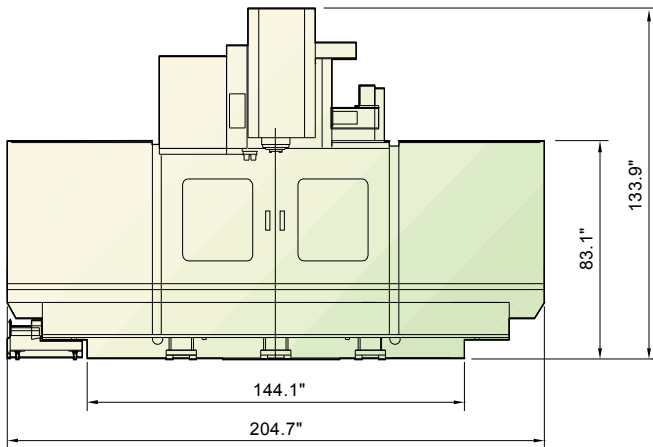

**STANDARD ACCESSORIES**

- M.P.G. Hand Wheel
- Two Speed Geared Head
- Chip and Coolant Guard
- One Set of Chip Conveyor
- Two Sets of Chip Auger
- Dilmatic Spindle Cooling System
- 30 Tool Magazine
- Coolant System
- Oil Skimmer
- Cutting Air Blast
- Spindle Air Blast
- Hydraulic Unit
- Central Lubrication System
- Pilot Lamp
- Working Lamp
- Tool Kits
- Leveling Blocks and Bolts
- Mechanical, Electrical & Operating Manual
- Way Cover (X, Y, Z)

**OPTIONAL ACCESSORIES**

- Optical Scales
- Chip Enclosure
- Chip Enclosure and Auto Door
- 4<sup>th</sup> Axis Rotary Table
- Mist Coolant System
- Heat Exchanger for Control Cabinet
- Workpiece Measurement System (RENISHAW MP-10)
- Coolant Through Spindle System (DIN 69871 Form-B)
- Automatic Tool Length Measurement (METROL T-24E-01)
- Transformer

**SPECIFICATIONS**

■ **SPINDLE**

Motor	FANUC AC Digital Spindle Motor
Horse Power	30 HP
Maximum Speed	6,000 rpm

■ **TRAVEL**

X Axis	82.6"
Y Axis	40.1"
Z Axis	30.0"

■ **TABLE**

Table Size	90.6" x 40.1"
Load Capacity	15,000 lb.
Number of T-Slots x Size x Pitch	6 x 0.87" x 6.3"

■ **FEED RATE**

Rapid Feed Rate	X,Y,Z : 472 ipm
Cutting Feed Rate	0.04 - 197 ipm

■ **ATC**

Tool Type	CAT-50 / BT-50 (Optional)
Maximum Tool Weight	44 lb./each
Maximum Tool Length	13.78"
Tool Magazine Capacity	30 (40 optional)

■ **ACCURACY (Linear)**

Table Positioning	± 0.00016"
Repeatability	± 0.00008"

■ **GENERAL**

Power Requirement	220V, 3 Phase, 60Hz
Power Consumption	45 kVA
Pneumatic Pressure	85 psi (minimum)
Machine Weight	55,000 lb.

**Note:** The manufacturer reserves the right to modify the design, specification, mechanisms...etc. to improve the performance of the machine without notice. All the specifications shown above are just for reference.

**DEALER:**



**YCI Inc.**

10629 Forest Street, Santa Fe Springs, CA 90670

TEL 562.906-6118 FAX 562.906-6107

ISO 9001, 14001 Certified Manufacturer

Web Page: [www.ycisupermax.com](http://www.ycisupermax.com) E-mail: [sales@ycisupermax.com](mailto:sales@ycisupermax.com)